

# clarion

## PSW-D-DG/G Camouflage Powered Subwoofer

### DODGE DURANGO Fits All Dodge Durango Models 1997 to 2000

## PREPARATION

### Parts list

(Qty) Component

#### Preassembled

- (1) Roto-molded subwoofer enclosure
- (1) 8"; 2 ohm subwoofer
- (1) 100W class "D" amplifier
- (1) Speaker grille

#### Loose Components

- (1) 17' wire harness w/ pigtail style connector
- (3) 3/4" pilot point wafer Phillips head screws
- (3) Color Matched Panel Clips

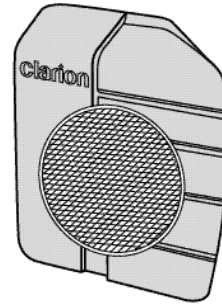

### WIRING:

1	Green	Left + Speaker Level Input
2	Violet/Blk	Right - Speaker Level Input
3	Green/Blk	Left - Speaker Level Input
4	Violet	Right + Speaker Level Input
5	Blank	Not Used
6	Black	Chassis Ground
7	Blue	Amplifier Turn-on Lead
8	Yellow	+ 12V Constant

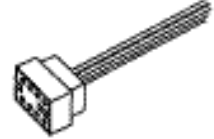
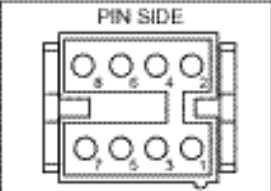

Note: Installer MUST disconnect speaker-input leads to amplifier when using line-level input

## OVERVIEW

The Clarion Camouflage subwoofer system provides for the installation of a low frequency driver in an enclosure which is powered by a small low current, high power class "D" (Digital) amplifier. The advantage to using this type of amplifier is in the low current consumption of the amplifier at high power levels. The class "D" amplifier provided with this system will produce a rated 100W into a 2 ohm load. The woofer supplied with this system uses a voice coil with rated impedance of 2 ohms, and therefore is not considered a standard woofer. Replacing the woofer with any driver having an impedance greater than 2 ohms will yield lower power output from the amplifier, and is not recommended.

## PROCEDURE

Proper installation of this product requires proper tools and knowledge of car audio principles. If you are not comfortable performing any of the outlined tasks below, contact a professional installation facility to perform the work.

### OUTLINE

- Remove the head unit.
- Connect the Clarion "T" harness between the radio and factory wiring and route the harness extension to rear passenger side of the vehicle.
- Remove rear quarter trim panel.
- Install subwoofer enclosure.
- Test subwoofer enclosure and head unit functions (fade, balance, dim, etc.).
- Adjust subwoofer gain.

THIS DEVICE COMPLIES WITH PART 15 OF THE FCC RULES. OPERATION IS SUBJECT TO THE FOLLOWING TWO CONDITIONS.

- (1) THIS DEVICE MAY NOT CAUSE HARMFUL INTERFERENCE, AND
- (2) THIS DEVICE MUST ACCEPT ANY INTERFERENCE RECEIVED, INCLUDING INTERFERENCE THAT MAY CAUSE UNDESIRABLE OPERATION.

## 1a. WIRING USING A CLARION "T" HARNESS

There are 2 methods to connect this product to the vehicle. Please refer to section 1a and 1b for each.

### • STEP 1:

Remove the Radio.

### • STEP 2:

Connect the "T" Harness.

- Unplug factory wires from radio.
- Plug the "T" harness in line with the radio wiring. SEE DIAGRAM 1.
- Connect the BLACK wire on "T" harness to radio chassis.

### • STEP 3:

Route the wire harness from the radio to the rear passenger side of the vehicle.

### •STEP 4:

Connect the amplifier ground wire to a clean chassis ground near the subwoofer enclosure.

### STEP 5:

TEST and SET the GAIN.

- Turn on the system and be sure all speakers are working properly.
- Set the subwoofer amplifier gain to a suitable level.

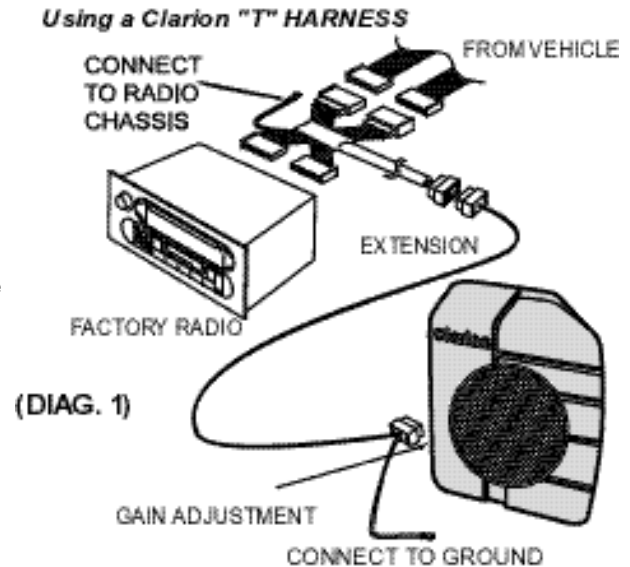

## 1b. WIRING USING THE SUPPLIED HARNESS

### • STEP 1:

Remove the Radio.

### • STEP2:

Connect the wires.

- Yellow: Connect to Constant 12V Power  
Black: Connect to Radio Ground or Chassis  
Blue: Connect to Amp/Antenna Turn-on Lead  
Green: Connect to Left Rear Speaker (+) Positive Lead  
Green/Black: Connect to Left Rear Speaker (-) Negative Lead  
Violet: Connect to Right Rear Speaker (+) Positive Lead  
Violet/Black: Connect to Right Rear Speaker (-) Negative Lead

### • STEP 3:

Route the wire harness from the radio to the rear passenger side of the vehicle.

### •STEP 4:

Connect the amplifier ground wire to a clean chassis ground near the subwoofer enclosure.

### STEP 5:

TEST and SET the GAIN.

- Turn on the system and be sure all speakers are working properly.
- Set the subwoofer amplifier gain to a suitable level.

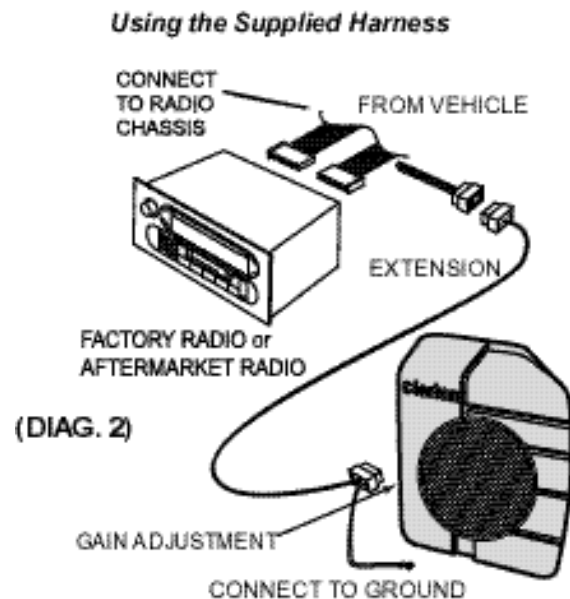

## II. RUN WIRE HARNESS

- A. Run harness to the rear passenger side quarter panel.
- B. Remove the rear quarter trim panel.
- C. Remove 12V-power outlet from quarter panel.
- D. Route wire harness through the hole left by removal of the power outlet.
- E. Ground 8" black wire on the 17' wire harness to the ground wire of the factory power outlet plug.

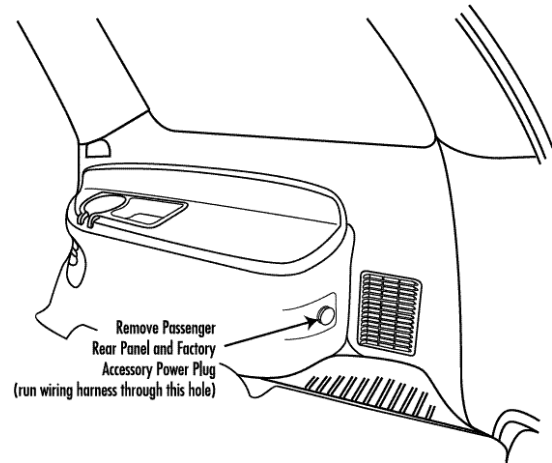

## III. TEST THE ENCLOSURE

- A. Plug in the wire harness to the enclosure.
- B. Plug in the "T" harness behind the radio (or hard wire the supplied 'pigtail' harness to the factory wiring).
- C. Test for proper operation.
- D. Gain the subwoofer enclosure (gain pod is located on the amplifier next to the wire harness connector, and is adjustable with a Phillips screw driver).

## IV. ATTACH THE ENCLOSURE TO THE REAR QUARTER PANEL

- A. Place the enclosure onto the quarter trim panel so that it fits snug to the panel.
- B. Install three screws into the enclosure from the rear side of the quarter trim.

*(Note: Three color matched panel clips have been supplied to conceal the holes left by the installation. They should be placed into the poly bag and taped into the vehicle behind the quarter trim panel. They will be used if the enclosure is ever removed from the vehicle. The holes will need to be enlarged to 1/4" to allow these panel clips to attach to the trim-panel during the removal of this enclosure.)*

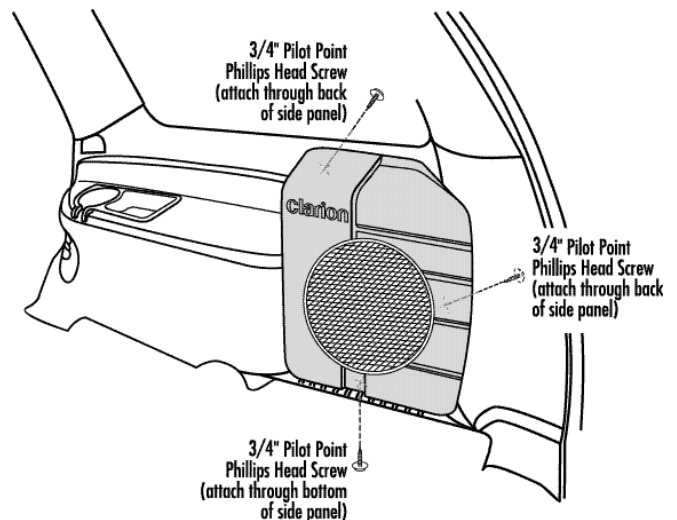

## V. REASSEMBLE THE VEHICLE

- A. Make sure all the wires are hidden. Then do the process in reverse order.

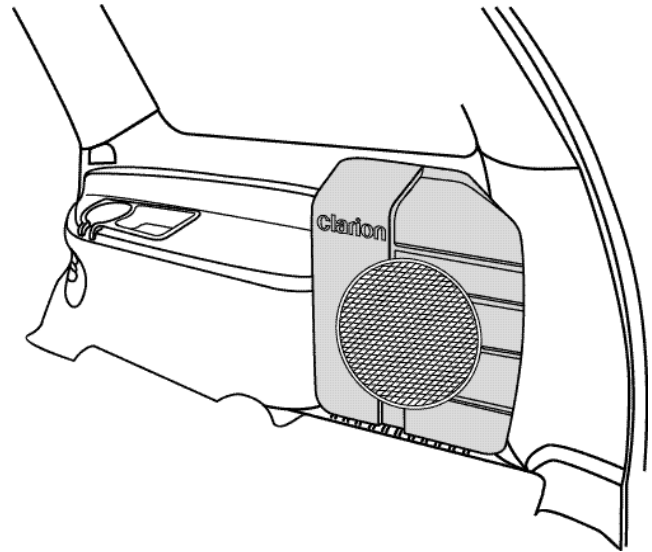

Clarion Corporation of America  
661 West Redondo Beach Blvd Gardena, CA 90247  
800-Go-Clarion  
www.clarion-usa.com © 2000 Clarion Corporation, Gardena, CA